

PITELUMEC

Thumper 180 DOWN THE HOLE HAMMER



THUMPER 180 FOR HOLE DIAMETER 460 - 610MM

PNEUMEC THUMPER 180 18" DOWN THE HOLE HAMMER

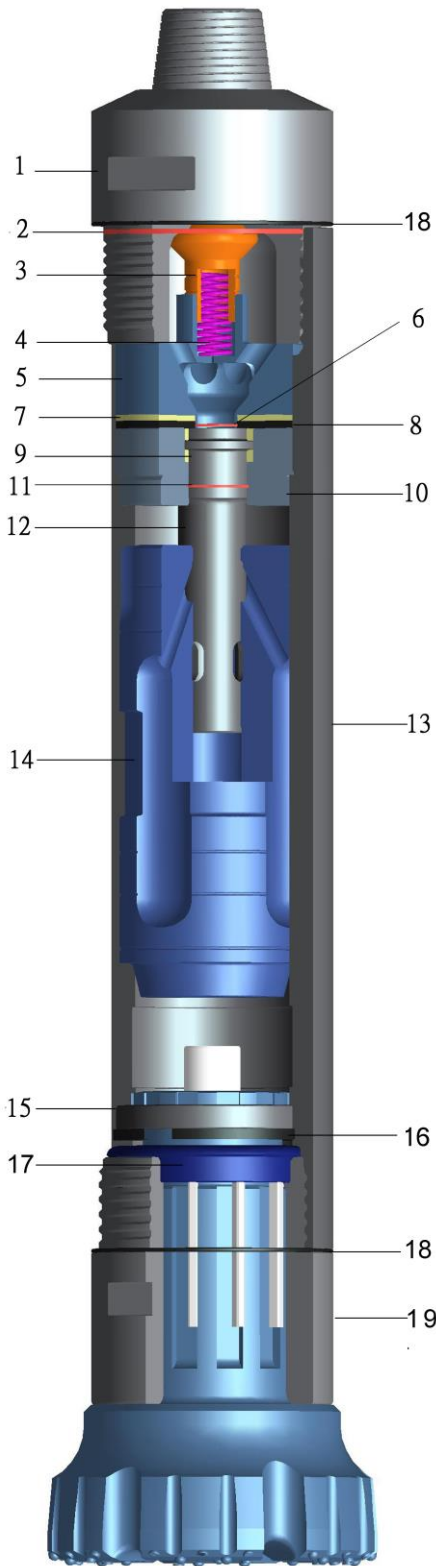

THUMPER 180 HAMMER PARTS LIST

1.	BACKHEAD 8-5/8" API REG PIN	HSP18S1T6M
2.	BACKHEAD "O" RING	HSP18S2
3.	CHECKVALVE	HSP18S3
4.	CHECK VALVE SPRING	HSP18S4
5.	VALVE CHEST	HSP18S5
6.	MAKE UP PLATE "O" RING	HSP18S6
7.	MAKE UP RING	HSP18S22
8.	MAKE UP PLATE	HSP18S23
9.	CONTROL TUBE RING (2)	HSP18S10
10.	CONTROL TUBE HOLDER	HSP18S7
11.	TUBE HOLDER SEAL	HSP18S20
12.	CONTROL TUBE	HSP18S8
13.	WEARSLEEVE	HSP18S18
14.	PISTON	HSP18S12N18
15.	GUIDE BUSH	HSP18S26
16.	PISTON RING	HSP18S25
17.	BIT RETAINERS	HSP18S15N18
18.	WASHER (2)	HSP18S21
19.	CHUCK N180	HSP18S19N18
20.	COMPLETE HAMMER N180	HAM18SN18THP

THUMPER 180 HAMMER SPECIFICATIONS

DIAMETER	406MM
LENGTH	2209MM
PISTON WEIGHT	310KG
HAMMER WEIGHT	1,680KG
HOLE DIAMETER	460MM – 610MM
BACKHEAD CONNECTION	8-5/8" API REG PIN
SHANK TYPE	N180

THUMPER 180 HAMMER AIR CONSUMPTION

PRESSURE (BAR / PSI)	CFM	M ³ /MIN
6.9 / 100	1200	34
10.3 / 150	1680	47.6
13.8 / 200	2320	65.7
15.2 / 225	3300	93.5

PNEUMEC

PNEUMEC COMPANY LIMITED

1st Floor, Tin On Sing Comm. Bldg., 41-43 Graham St. Central, H.K.

Tel : (852) 2180 9922

Fax : (852) 2180 9982

Website : www.pneumec.com

email : info@pneumec.com